

EV8626

Note counter

Built for speed, accuracy and efficiency

The optimization of cash management calls for specialist experience, resources and truly innovative technology. Across the world, Talaris' cash management solutions are trusted by thousands of organizations to ensure their cash is managed securely and efficiently while delivering the ultimate in productivity.

The EV8626 exemplifies performance and value. Its ease of use and accuracy means you can count your notes efficiently, saving you time and money.



Commercial grade EV86 Series note counters are designed and built to be fast, accurate and robust. This means you can count your notes efficiently and quickly with few interruptions, saving time and money.

Speed and throughput

EV8626 will accept a range of notes in various conditions because its UltraFeed™ “wing” design helps notes pass through the counter with ease. This minimizes stops caused by the need to re-feed notes that other note counters would not accept. UltraFeed allows EV8626 to produce a very high level of throughput.

Accurate feed

The intelligence of Mechanical Doubles Detection™ (MDD) also enhances throughput. This patented MDD technology enables the note

counter to recognize and accurately count doubles or chain notes that overlap during feeding.

Robust build and a premium look and feel

From the metal side plates and sheet metal running through the heart of the machine, to the ergonomic handle and user-friendly keypad, EV8626 is a robust and reliable note counter. The premium look and feel also help make it the best choice for all your note counting needs.

Talaris’ note processing products are the direct result of over 100 years of experience in the design, manufacturing and distribution of world class note processing machines.

Talaris Technology
Talaris’ unique technology sets new industry standards

UF™
ultra feed

Maximizing feed efficiency, ensuring that all banknotes are fed consistently irrespective of design and quality of condition.

MDD™
mechanical double detection

Right First Time. Every Time.
Most accurate counting technology in the world.
Decisive counting; low stop-rates.
Less re-feeding, less frustration.

Weight
16.5 lbs
(7.5 kg)

10.43”
(264.92 mm)

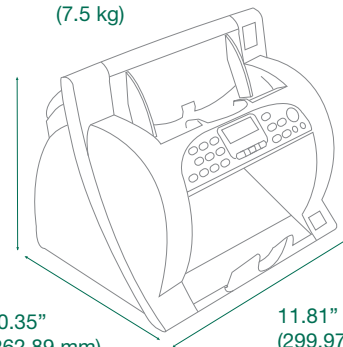

10.35”
(262.89 mm)

11.81”
(299.97 mm)



Product specifications

Speed range	800 - 1,500 notes per minute	Dimensions (H x W x D)	10.43” x 11.81”x 10.35”
Feed Technology	UltraFeed™	Weight	16.5 lbs
Count accuracy technology	Mechanical Doubles Detection™ (MDD)	Power supply	98 – 264V AC, 50/60 Hz
Capacity	Feed Hopper = 500 notes Output Stacker = 200 notes	List of Variants	EV8626 Std
Keypad	Numeric keypad with full travel keys		

North American Headquarters
2441 Warrenville Road
Lisle, IL 60532
United States
T +1 800.527.2638
www.talaris.com

